

**GROUP 100 BRAZED TOOLS**

**KENNEDY Brazed Tip Turning & Boring Tools**

Manufactured in three standard grades. (All sizes are nominal.)  
Manufactured to **ISO DIN BHMA Standards**.

**P40** **P40:** Roughing to heavy roughing of steel and steel castings using heavy feeds and low to medium cutting speeds. Also used under unfavourable conditions, particularly where intermittent cutting is involved. This grade is also suitable for planing operations and for machining manganese steel.

**P30** **P30:** Carbide tipped tools are suitable for heavy duty turning and boring on all classes of steel. Suitable also for interrupted cutting and machining at low speeds and heavy feeds.

**K20** **K20:** General purpose tools for most applications. Ideal for machining cast iron, non-ferrous metals, bakelite etc. Combines wear resistance with toughness when rough turning at moderate cutting speeds. Suitable for high feed rates.

**CUTTING TOOLS**

**Straight Round Nosed Turning Tools**



Tool No.	Cut	Shank Height x Width	Weight each	Order Code <b>KEN-100</b>			Price/1 TB
				P40	P30	K20	
010	N	3/8" x 3/8"	160g	-	-0100K	-0110K	1055.00
012	N	1/2" x 1/2"	190g	-	-0140K	-0150K	1065.00
016	N	5/8" x 5/8"	240g	-	-0190K	-0200K	1361.00
020	N	3/4" x 3/4"	410g	-	-0230K	-0240K	1681.00
024	N	1" x 3/4"	520g	-	-0270K	-	1965.00
026	N	1" x 1"	760g	-	-0310K	-	2368.00

**Cranked Round Nosed Turning Tools**

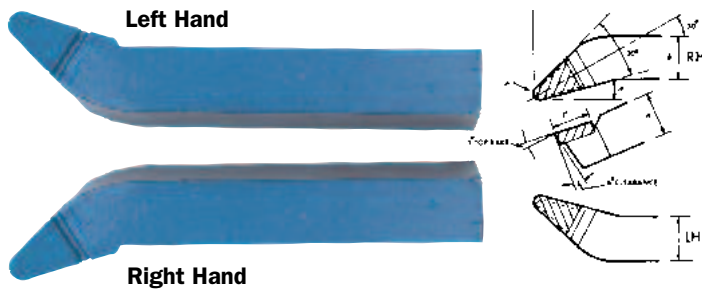

Tool No.	Cut	Shank Height x Width	Weight each	Order Code <b>KEN-100</b>			Price/1 TB
				P40	P30	K20	
12	RH	1/2" x 1/2"	110g	-	-0510K	-0520K	1491.00
13	LH	1/2" x 1/2"	110g	-	-0530K	-0540K	1491.00
16	RH	5/8" x 5/8"	240g	-	-0590K	-0600K	1563.00
17	LH	5/8" x 5/8"	240g	-	-0610K	-	1563.00
20	RH	3/4" x 3/4"	410g	-	-0690K	-0700K	1965.00
21	LH	3/4" x 3/4"	410g	-	-0710K	-0720K	1965.00
26	RH	1" x 1"	720g	-	-0820K	-	2311.00
27	LH	1" x 1"	720g	-	-0840K	-	2311.00

**Light Turning & Boring Tools**

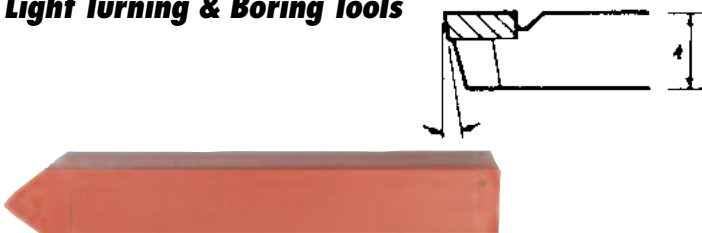

Tool No.	Cut	Shank Height x Width	Weight each	Order Code <b>KEN-100</b>			Price/1 TB
				P40	P30	K20	
40	N	3/8" x 3/8"	70g	-	-1000K	-	1136.00
44	N	1/2" x 1/2"	120g	-	-1060K	-1070K	1313.00
60	N	3/4" x 3/4"	430g	-	-1660K	-	1787.00

**Bar Turning Tools**

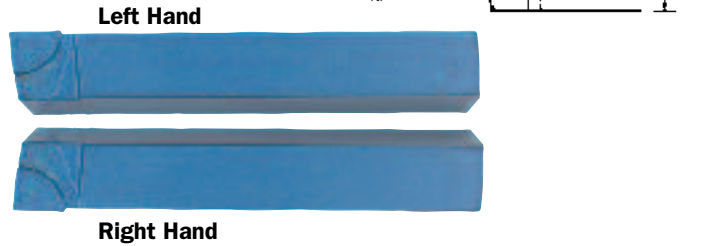
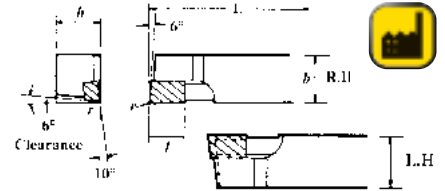

Tool No.	Cut	Shank Height x Width	Weight each	Order Code <b>KEN-100</b>			Price/1 TB
				P40	P30	K20	
100	RH	3/8" x 3/8"	70g	-	-2010K	-	1018.00
101	LH	3/8" x 3/8"	70g	-	-2040K	-	1018.00
102	RH	1/2" x 1/2"	120g	-2055K	-2060K	-2080K	1136.00
103	LH	1/2" x 1/2"	120g	-	-2100K	-2110K	1136.00
106	RH	5/8" x 5/8"	260g	-	-2180K	-	1444.00
110	RH	3/4" x 3/4"	440g	-	-2280K	-2290K	1634.00
111	LH	3/4" x 3/4"	440g	-	-2300K	-	1634.00

**Bar & Knee Turning Tools**

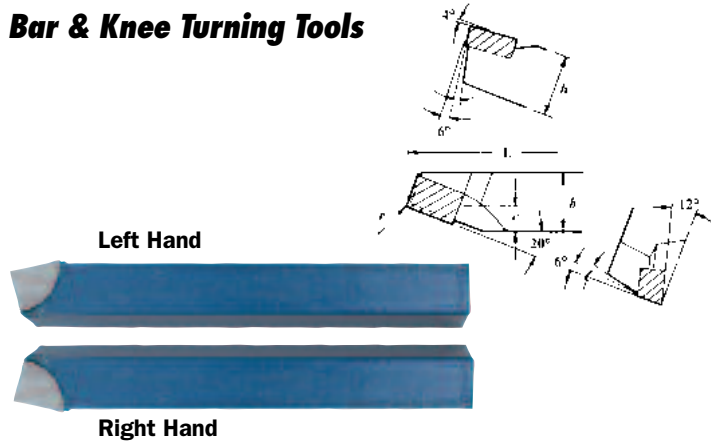

Tool No.	Cut	Shank Height x Width	Weight each	Order Code <b>KEN-100</b>			Price/1 TB
				P40	P30	K20	
132	RH	1/2" x 1/2"	120g	-	-2550K	-	1563.00
140	RH	3/4" x 3/4"	430g	-	-2610K	-	1669.00
141	LH	3/4" x 3/4"	430g	-	-2630K	-	1787.00

**Cranked Turning Tools**

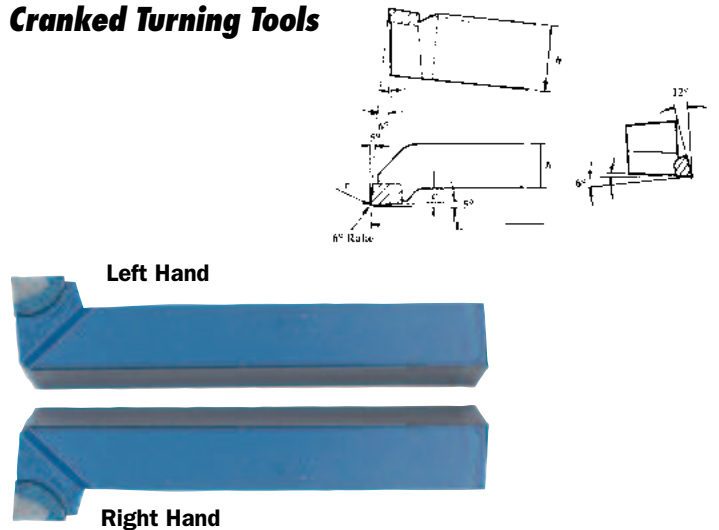

Tool No.	Cut	Shank Height x Width	Weight each	Order Code <b>KEN-100</b>			Price/1 TB
				P40	P30	K20	
160	RH	3/8" x 3/8"	70g	-	-2780K	-2790K	1255.00
161	LH	3/8" x 3/8"	70g	-	-2800K	-	1255.00
162	RH	1/2" x 1/2"	130g	-	-2830K	-2860K	1283.00
163	LH	1/2" x 1/2"	130g	-	-2870K	-2880K	1313.00
166	RH	5/8" x 5/8"	270g	-	-2940K	-2960K	1563.00
167	LH	5/8" x 5/8"	270g	-	-	-2990K	1669.00
170	RH	3/4" x 3/4"	460g	-	-3040K	-3070K	1906.00
171	LH	3/4" x 3/4"	460g	-	-3080K	-3090K	1906.00



**Brazed Tip Cranked Turning & Facing Tools**

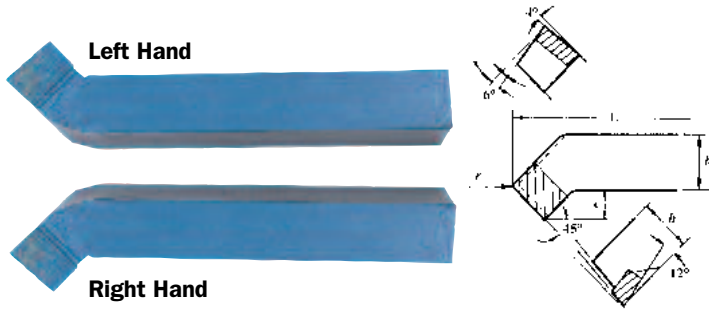

Tool No.	Cut	Shank Height x Width	Weight each	Order Code KEN-100			Price/1 TB
				P40	P30	K20	
192	RH	1/2" x 1/2"	110g	-	-3410K	-3420K	1373.00
196	RH	5/8" x 5/8"	260g	-3490K	-3500K	-	1610.00
197	LH	5/8" x 5/8"	260g	-	-3520K	-	1610.00
200	RH	3/4" x 3/4"	430g	-3680K	-3690K	-3710K	2000.00
201	LH	3/4" x 3/4"	430g	-	-3720K	-	2000.00
206	RH	1" x 1"	790g	-	-	-3850K	2794.00
207	LH	1" x 1"	790g	-3855K	-	-	2794.00

**Straight Recessing Tools**

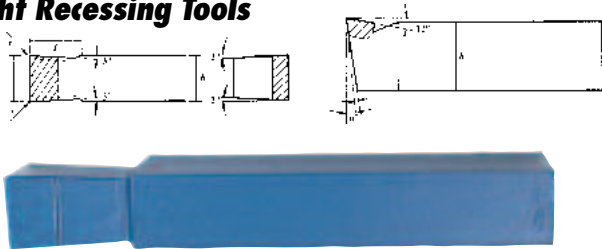

Tool No.	Cut	Shank Height x Width	Weight each	Order Code KEN-100			Price/1 TB
				P40	P30	K20	
230	N	3/8" x 3/8"	64g	-	-4370K	-	1136.00
232	N	1/2" x 1/2"	120g	-	-4460K	-	1402.00
236	N	5/8" x 5/8"	250g	-	-4620K	-	1610.00

**Parting Off Tools**

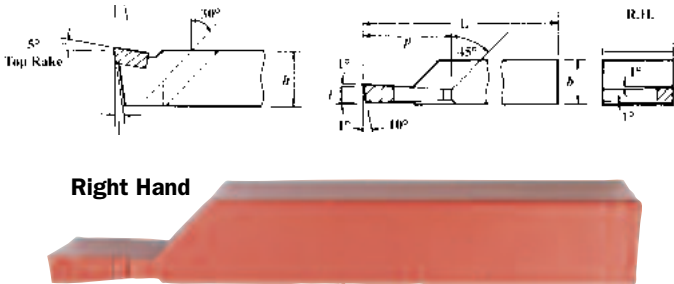

Tool No.	Tip	Shank Height x Width	Weight each	Order Code KEN-100			Price/1 TB
				P40	P30	K20	
260	3/32"	5/8" x 3/8"	120g	-5200K	-5210K	-5220K	2142.00
262	1/8"	3/4" x 1/2"	220g	-5260K	-5270K	-5280K	2142.00
264	3/16"	1" x 5/8"	390g	-5320K	-5330K	-5350K	2172.00
265	1/4"	1" x 3/4"	480g	-5420K	-5430K	-	2172.00
270	3/32"	5/8" x 3/8"	110g	-	-5610K	-	1610.00
272	1/8"	3/4" x 1/2"	220g	-	-5690K	-5710K	1462.00
274	3/16"	1" x 5/8"	390g	-	-5750K	-5770K	2107.00
275	1/4"	1" x 3/4"	460g	-5810K	-5820K	-5840K	2213.00
276	5/16"	1 1/4" x 3/4"	700g	-	-5880K	-5900K	3150.00

**Square Shank Boring Tools Held at 90° in Bar**



Tool No.	Cut	Shank H W	Weight each	Order Code KEN-100			Price/1 TB
				P40	P30	K20	
280	RH	1/4" x 1/4"	11g	-	-6180K	-	1160.00
288	RH	1/2" x 1/2"	109g	-	-6340K	-	1716.00

**Square Shank Boring Tools Held at 80° in Bar**

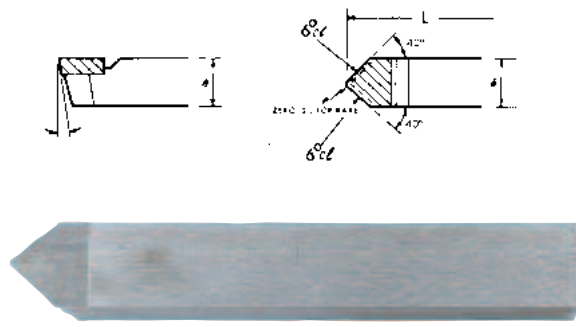

Tool No.	Cut	Shank H W	Weight each	Order Code KEN-100			Price/1 TB
				P40	P30	K20	
300	N	1/4" x 1/4"	11g	-	-6580K	-	1313.00
308	N	3/8" x 3/8"	16g	-	-6750K	-	1491.00
316	N	1/2" x 1/2"	109g	-	-6920K	-	1847.00

**Light Duty Round Shank Boring Tools Used at 45° in Bar**

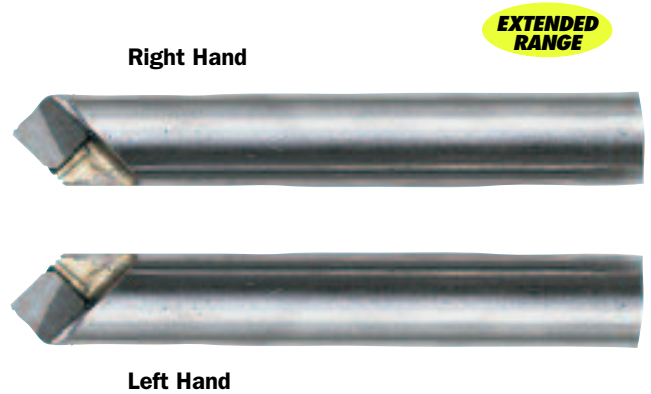

Tool No.	Cut	Shank Dia. x Length	Weight each	Order Code KEN-100			Price/1 TB
				P40	P30	K20	
375	LH	5/16" x 1 1/2"	13g	-	-8110K	-	1236.00
376	RH	3/8" x 2 1/2"	30g	-	-8130K	-	1339.00
377	LH	3/8" x 2 1/2"	30g	-	-8150K	-8160K	1339.00
380	RH	1/2" x 5"	65g	-	-8220K	-	1442.00

**Cranked Knife Turning Tools**

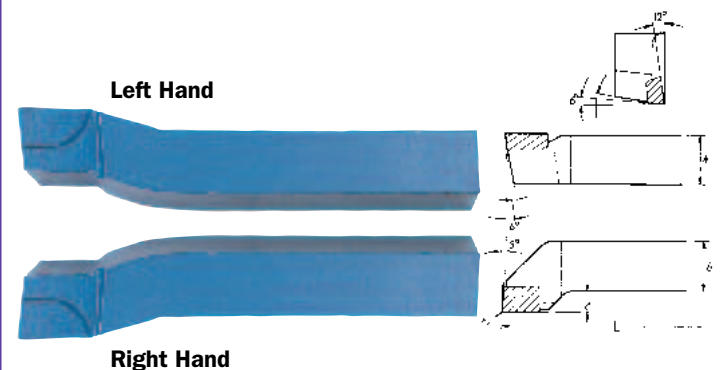

Tool No.	Cut	Shank Height x Width	Weight each	Order Code KEN-100			Price/1 TB
				P40	P30	K20	
2130	RH	3/8" x 3/8"	70g	-	-8970K	-	1236.00
2132	RH	1/2" x 1/2"	120g	-	-9010K	-9020K	1373.00
2133	LH	1/2" x 1/2"	120g	-	-9030K	-	1373.00
2136	RH	5/8" x 5/8"	260g	-	-9230K	-9250K	1639.00
2137	LH	5/8" x 5/8"	260g	-	-9260K	-	1639.00
2140	RH	3/4" x 3/4"	430g	-9380K	-9390K	-9400K	2013.00
2141	LH	3/4" x 3/4"	430g	-	-9420K	-	2013.00
2146	RH	1" x 1"	800g	-	-9670K	-	3208.00